

Tensione massima	48 Vca/cc	Max voltage	48 Vac/dc
Intensità di corrente	0,5(0,2)A	Current	0.5(0.2)A
Membrana	Vedi tabella membrane	Diaphragm	See reference list below
Campo di temperatura	-30°C...+140°C (in funzione della membrana)	Temperature range	-30°C to +140°C (according to diaphragm material)
Max. n° d'interventi a 25°C	200/1'	Max. cycles rate at 25°C	200/min
Protezione fast-on	IP00 vedi pagina 54	Protection (terminals)	IP00 see page 54
Protezione con CAP1 - CAP10	IP54 vedi pagina 54	Protection with CAP1 - CAP10	IP54 see page 54
Protezione con CAP3	IP65 vedi pagina 54	Protection with CAP3	IP65 see page 54
Corpo porta contatti	PA 66	Switch housing	PA 66
Vita meccanica	10 ⁶ cicli	Mechanical life	10 ⁶ operations
Prova di rigidità	1500V - 10 mA - 10"	Strength test	1500V - 10 mA - 10"
Coppia di serraggio consigliata	Max. 4 Kgm. vedi pagina 3	Recommended tightening torque	Max. 4 Kgm. see page 3

CAPPUCCI DI PROTEZIONE / PROTECTION CAPS

PROTEZIONE IP 54 / IP 54 PROTECTION

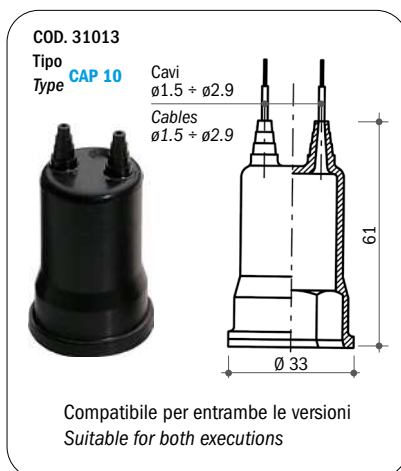
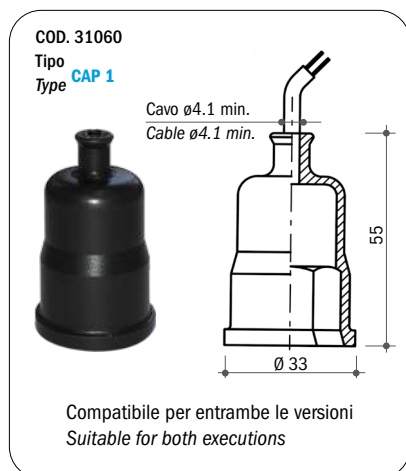

PROTEZIONE IP 65 / IP 65 PROTECTION

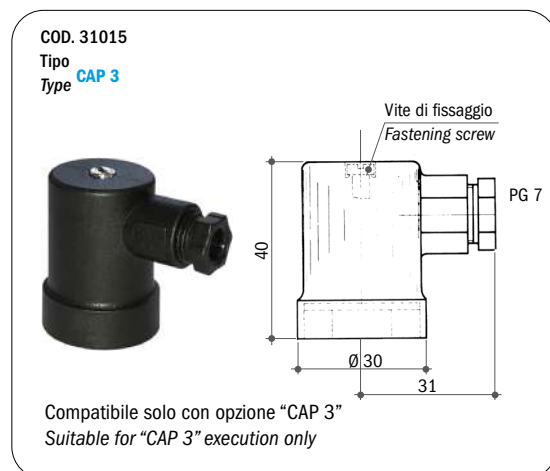

DATI TECNICI GENERALI GENERAL TECHNICAL DATA

PRESSOSTATO A MEMBRANA, CONTATTO NC /
MEMBRANE PRESSURE SWITCH, NC CONTACT

SENZA PRESSIONE
WITHOUT PRESSURE

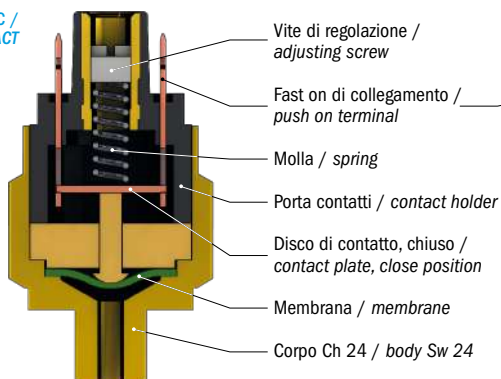

CON PRESSIONE
WITH PRESSURE

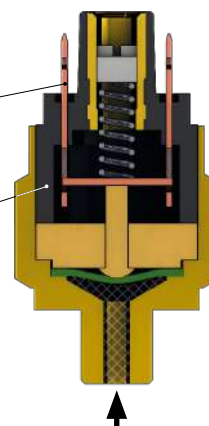

PRESSOSTATO A MEMBRANA, CONTATTO NA /
MEMBRANE PRESSURE SWITCH, NO CONTACT

SENZA PRESSIONE
WITHOUT PRESSURE

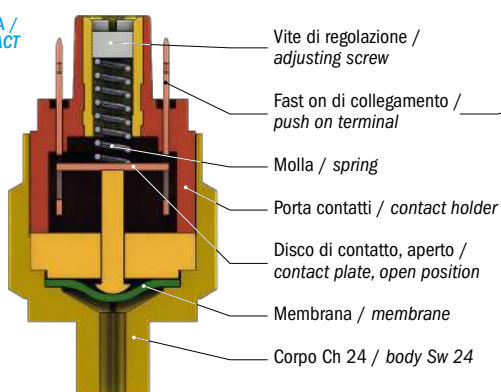

CON PRESSIONE
WITH PRESSURE

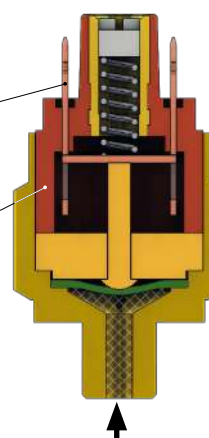

COPIE DI SERRAGGIO CONSIGLIATE / RECOMMENDED TIGHTENING TORQUES

Ottone / Brass		Acciaio zincato / Zinc plated carbon steel		AISI 316 / S.S. 316	
Filetto Thread	Coppia di serraggio* Recommended tightening torque Nm	Filetto Thread	Coppia di serraggio* Recommended tightening torque Nm	Filetto Thread	Coppia di serraggio* Recommended tightening torque Nm
R18	17	R18	22	R18	24
18K	17	18K	22	18K	24
18NPT	17	18NPT	22	18NPT	24
5/8UNF	30	5/8UNF	40	5/8UNF	45
R12	40	R12	55	R12	60
R14	25	R14	35	R14	40
14K	25	14K	35	14K	40
14NPT	25	14NPT	35	14NPT	40
M10	18	M10	25	M10	30
M12	23	M12	32	M12	35
10K	18	10K	25	10K	30
34K	50	34K	70	34K	80

TIPOLOGIA DI CONTATTI ELETTRICI UTILIZZATI / ELECTRICAL CONTACTS APPLIED









			Normativa DIN-EN-60947-5-1 Standard DIN-EN-60947-5-1	Simbolo IEC 60617 Symbol IEC 60617
NA	NA normalmente aperto NO normally open	SPST (single pole, single throw)	X	
NC	NC normalmente chiuso NC normally closed	SPST (single pole, single throw)	Y	
SC	SC contatti in scambio CO change over (snap action)	SPDT (single pole, double throw)	C	

* Una scorretta coppia di serraggio può influenzare la durata della macchina del pressostato. Elettrotec limita la sollecitazione tollerata dal materiale a una percentuale della sollecitazione di snervamento. Variando tipologia di materiale utilizzato per realizzare il corpo del pressostato, varierà anche la coppia di serraggio.

* Improper torque may affect the mechanical life of the switch. The relevant legislation has been expressed in various ways. Elettrotec limits the stress tolerated by the material to a percentage of the yield point. By varying the type of material used to make the switch body, will also vary the tightening torque.

VUOTOSTATI / VACUUM SWITCHES

PROTEZIONI ELETTRICHE / ELECTRIC PROTECTIONS

		VCN	VCM	VS	VSM	VMC
Pagina / Page		55	57	59	61	63
Protezione IP 54 / IP 54 electric protection	CAP 1 	●	●			
	CAP 10 	●	●			
	CAP 12 				●	
	CAP 16 			●		
Protezione IP 65 / IP 65 electric protection	CAP 3 		●			
	CAP 13 			●		
	Connettore Din 40050 / Din 40050 Connector 				●	●
Protezione IP 67 / IP 67 electric protection	Cap 14 + Cavi + Connettore Cap 14 + Flying Leads + Connector 			●		
	Connettore M12 / M12 Connector 			●		

DATI TECNICI / TECHNICAL DATA

		VCN	VCM	VS	VSM	VMC
Tensione di alimentazione / Power supply	12 Vca/cc	●	●	●	●	●
	24 Vca/cc	●	●	●	●	●
	48 Vca/cc	●	●	●	●	●
	110 Vca/cc			●	●	●
	220 Vca/cc			●	●	●
	250 Vca/cc			●	●	●
Corrente massima / Max. current	< 30 mA	●	●	●	●	●
	0,5 A	●	●			
	3 A					●
	6 A			●	●	
Contatti argentati / Silver plated contacts		●	●	●	●	●
Contatti dorati / Gold plated contacts		●	●	●	●	●
Isteresi fissa / Fixed Hysteresis		●	●	●		●
Isteresi regolabile / Adjustable Hysteresis					●	
Corpo CH. 24 / Body 24 AF		●	●	●		
Corpo CH. 27 / Body 27 AF					●	

Elettrotec si riserva la facoltà di apportare modifiche tecniche ai prodotti o di cessarne la produzione senza obbligo di preavviso. Il contatto del pressostato può danneggiarsi quando sottoposto a forti urti o ad alte vibrazioni. È responsabilità dell'utilizzatore verificare l'idoneità dei nostri prodotti per ogni particolare applicazione (ad esempio, la verifica della compatibilità dei materiali) e l'uso può essere appropriato solo se dimostrato in test sul campo. Le informazioni tecniche in questo catalogo si basano su prove effettuate durante lo sviluppo del prodotto e in base ai valori empiricamente raccolti. Essi non possono essere applicabili in tutti i casi.

Elettrotec reserves the right to technical data of change to the products or halt production without prior notice. The pressure switch contacts can be damaged when subject to strong shocks or high vibration. It is the responsibility of the user to test the suitability of our products for the particular application, for example, the verification of material compatibility. The use may only be appropriate if proven in field tests. The technical information in this catalogue are based on tests made during product development and based on empirically gathered values. They may not be applicable in all cases.