

# Newdeal AIR TAKE-OFF

The air take-off has the job to take off the air from the Newdeal FRL unit irrespective of the position where it is assembled. It is required whenever you need to take off air from the FRL unit at different stages of the treatment (normal, filtered, filtered regulated, lubricated, etc.)



## TECHNICAL DATA

		PA ND 1/4"	PA ND 3/8"	PA ND 1/2"	PA ND 3/4"	PA ND 1"
Threaded port		1/8"		1/4"		1/2"
Maximum working temperature at: 1 MPa; 10 bar; 145 psi	°C	50		50		50
	°F	122		122		122
Maximum admissible pressure	MPa	1.8		1.8		1.8
	bar	18		18		18
	psi	261		261		261
Weight	kg	0.06		0.18		0.41

## DIMENSIONS

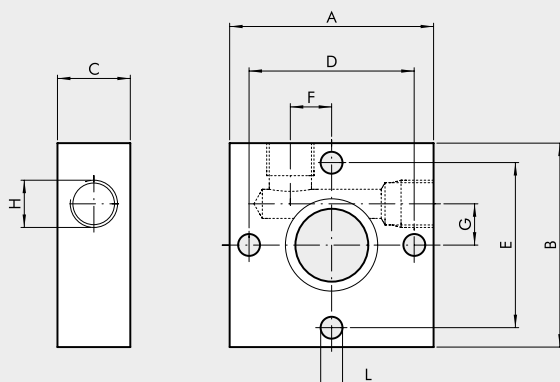

	PA ND 1/4"	PA ND 3/8"	PA ND 1/2"	PA ND 3/4"	PA ND 1"
Threaded port	1/8"		1/4"		1/2"
A	42		60		80
B	42		60		80
C	15		20		30
D	34		49		64
E	34		49		64
F	8.5		14		16
G	8.5		14		16
H (n° 2 pos.)	1/8"		1/4"		1/2"
L	Hole for M4 screws		Hole for M5 screws		Hole for M6 screws

## ORDERING CODES

Code	Description
9200401	PA 1/4 take-off
9400401	PA 1/2 take-off
9600401	PA 3/4 take-off

Comes with 2 screws for F/L and R/FR fixing.