

SELBSTFORMENDE SCHRAUBE

SELF FORMING SCREW

<p>Ausführung mit Torx</p> <p>Beschreibung zur Verbindung von zwei Aluminiumprofilen; für die Montage ist kein Gewindeschneiden erforderlich; durch die spezielle Form des Schraubenkopfes und des selbstformenden Gewindes entsteht eine leitfähige Verbindung zwischen den Profilen</p> <p>Material Stahl, verzinkt</p> <p>Liefereinheit 100 Stück</p>	<p>Model With Torx</p> <p>Description To connect two aluminum profiles; no thread cutter is necessary to fix the screw; because of the special form of the head of the screw and the self-forming thread, a conductive connection of two aluminum profiles is achieved</p> <p>Material Zinc plated steel</p> <p>Pack Quantity 100 pieces</p>
--	--

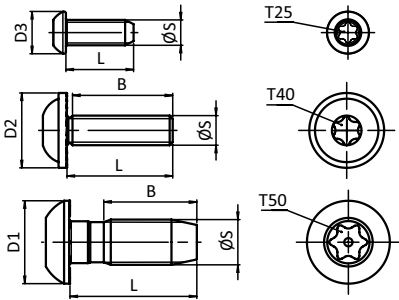

Selbstschneidende Schraube Self Forming Screw	B [mm]	D1 [mm]	D2 [mm]	D3 [mm]	Extras	Größe S × L [mm] Size S × L [mm]	Montage Assembly	Gewicht [g] Weight [g]	Profil Profile	Teil-Nr. Part #
	14.0			10.0		S6 × 16	Torx T25	4.0	B	093S0616T
	23.0		17.5		ESD	S7 × 25	Torx T40	11.0	I	093S0725T
	23.0		16.0		ESD	S8 × 25	Torx T40	12.0	B	093S0825T
	22.0	19.0			ESD	S12 × 30	Torx T50	25.2	B	093S1230T

