

TP - PRESS FIT FILLER BREATHERS

TPF - PRESS-FIT FILLER BREATHERS WITH FILTER

TPV - PRESS FIT FILLER BREATHERS WITH VENT VALVE

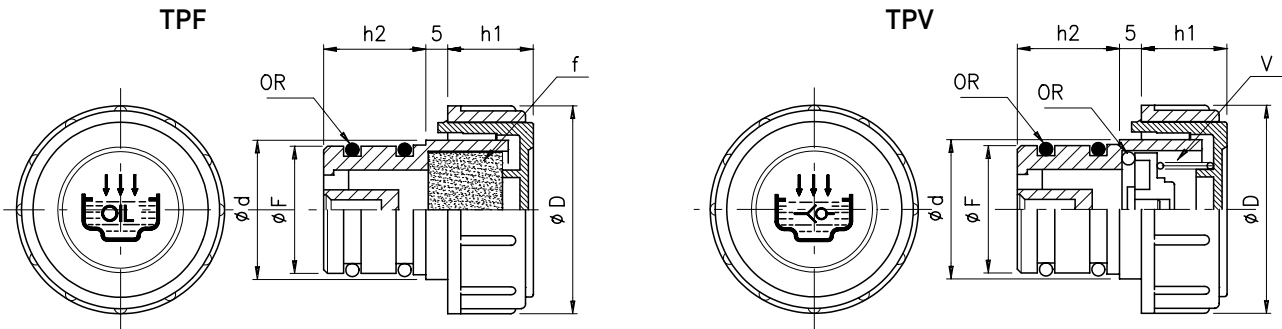

f = Air filter V = One-way check valve
OR = O-Ring NBR seal

- Press-fit filler breathers, with easy grip vertical ribs, they fit snugly into a pre-drilled hole and seal by means of two O-Rings seals located on the stem; hole tolerances $-0 +0,1$ mm.

- Manufactured from Polyamide 66 ensuring high mechanical resistance at both low and higher temperatures (max working temp. 100°C-212 F)

- The polyurethane air filter is located under the lid, easy to remove clean and reinstall; filtration degree 40 micron.

- Standard colour is black, red lid, with encased the graphic "fill" symbol and the text "OIL" (TP-TPF model), the TPV model also has the "vent valve" graphic symbol.

- The filler breathers model TP-TPF have a large breathing capacity and are suggested where a high volume of airflow takes place, for example hydraulic systems that utilize high ratio hydraulic cylinders; not recommended for usage on mobile equipment, where strong movement of the oil tank is present.

- The model TPV is equipped with a one-way vent valve, which opens when an overpressure of **0.20-0.25** bar takes place in the tank; under normal conditions of working this valve remains closed.

	Code	F	D	d	h1	h2
TP-18	TPF-18 TPV-18	18	36	23	17	20
TP-20	TPF-20 TPV-20	20	36	24	17	19
TP-26	TPF-26 TPV-26	26	41	28	17	21
TP-30	TPF-30	30	47	33	17	21