

LSB - DOME SHAPED OIL LEVEL GLASSES

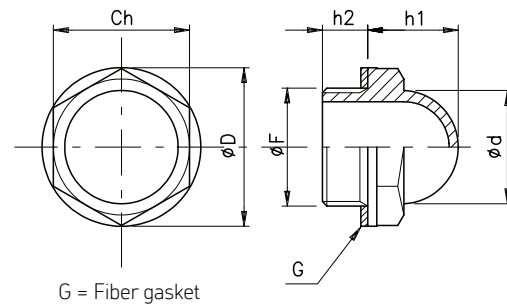

-Dome shaped transparent level glasses, enabling oil level to be read from any angle

-Made from transparent polyamide which provides good mechanical resistance and is impervious to mineral oil, gasoline, lubricants, petroleum, solvents and most chemical agents. Avoid contact with alcohol based solutions and anti-freeze liquids at high temperatures and hot water over 80 °C



-Fiber gasket (optional NBR flat seal on request).

-Dimensional stability up to temperature of 100°C
(temperature test made up to 1 bar/15 psi)

-Maximum tightening torque suggested for installation is indicated in the table (Nm)

Code	F	Ch	D	d	h1	h2	Nm
LSB-38	G 3/8"	19	22	15	14	10	8÷10
LSB-12	G 1/2"	24	28	20	18	10	12÷14
LSB-34	G 3/4"	30	35	25	20	10	16÷18
LSB-1	G 1"	36	42	31	24	10,5	18÷20
LSB-20.15	M 20x15	24	28	20	18	10	12÷14