

# VALVES SERIES 70, HAND OPERATED

TECHNICAL DATA		1/8"	1/4"	1/2"
Operating pressure range:				
• version with direct control	bar	Vacuum to 10		
• pilot-assisted version	bar	2.5 to 10		
Operating temperature range		°C -10 to +60		
Nominal diameter		mm 5	7.5	15
Conductance C	Nl/min · bar	121.43	264.26	971.43
Critical ratio b	bar/bar	0.32	0.27	0.43
Flow rate at 6 bar ΔP 0.5 bar	Nl/min	400	750	3200
Flow rate at 6 bar ΔP 1 bar	Nl/min	550	1100	4600

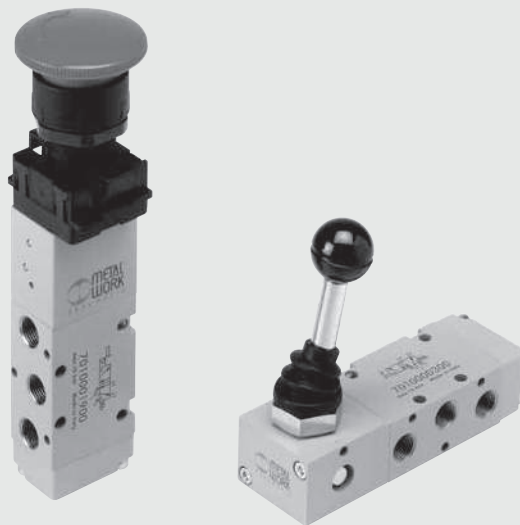

## SYNOPTIC, SIZES AND VERSIONS

MAV FAMILY	2 DIMENSIONS	3 FUNCTION	PP OPERATORS 14	S RESETTING (12)	NC FURTHER DETAILS
MAV manual valves	2 1/8"	3 3/2	PP drawer	A pneumatic/mechanical springs*	NC normally closed
	3 1/4"	5 5/2	VL axial lever	S mechanical springs	NO normally open
	4 1/2"	6 5/3	LE 90° lever	B bistable	OO no indication
		8 2 x 3/2	BRE arranged for manual panel actuators	D differential	CC closed centres
				O stable for 5/3	OC open centres
					PC pressure centres

\*on demand

## VALVES SERIES 70, HAND OPERATED, 1/8"

### FRONT LEVER 3/2, 1/8"

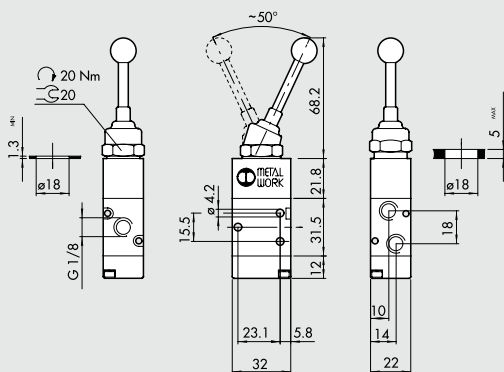

Symbol	Code	Abbrev.	Weight [g]
	7010001400	MAV 23 VLB OO	130